

## WZSA CLAMPS

**Application:**

The self positioning feature of these clamps enable the automation of QDC systems. The auto sliding clamps can be used on all presses, but they are recommended for presses with a higher number of clamps. This clamp can utilize existing U-slots, or can be mounted on the adapter plate (shown below). It also requires minimum clamping space on the die shoe.

**Features:**

- Suitable for narrow clamping edges
- Automatic positioning

- SAE-ORB porting for reusable, leakproof operation up to 6000 psi
- Sensor protected
- Suitable for retrofitting

**To Order:**

Note the type of clamp. Clamps are listed by clamping force, so please provide the information requested below by filling out the form on page 48.

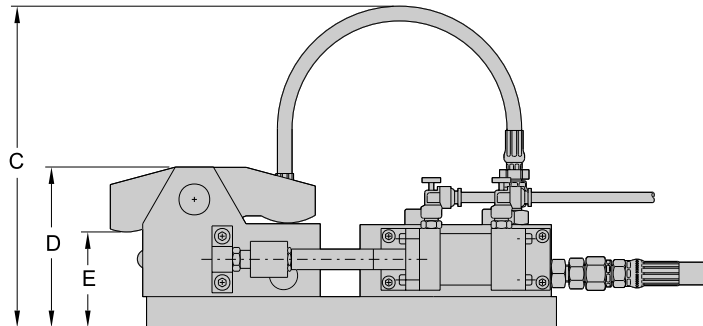
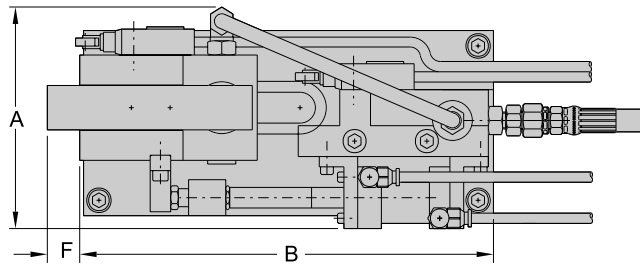

TYPE	Clamping force @3500 psi	Total stroke	Dimensions						Air cylinder stroke
			'A'	'B'	'C'	'D'	'E'	'F'	
UNIT	lbs	in	in	in	in	in	in	in	in
WZS20A	4400	.25	5.375	10.10	7.88	3.90	2.313	.79	1.0
WZS40A	8800	.25	6.375	11.25	8.56	4.57	3.125	.79	1.0
WZS70A	15400	.25	7.25	12.00	9.06	5.33	4.125	1.00	1.24