

# Auto positioning clamps

## SA CLAMP SWING ARM

**Application:**

Swing Arm Clamps are designed for clamping punch holders to the press ram. The swing arm clamp enables die change automation because it does not require manual operation to be set into work position.

**Features:**

- Durable design
- SAE-ORB porting for reusable, leakproof operation up to 6000 psi

- Application flexibility
- Suitable for retrofitting

**To Order:**

Note the type of clamp. Clamps are listed by clamping force, please provide the 'X' & 'Y' dimension requested below by filling out the form on page 48.



SA clamp

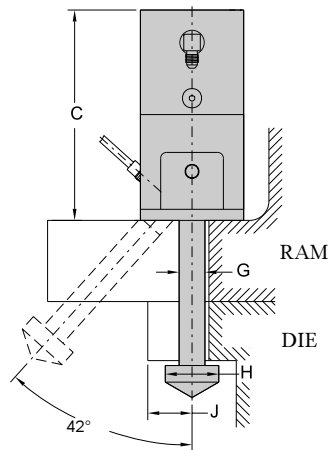
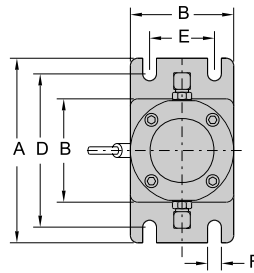
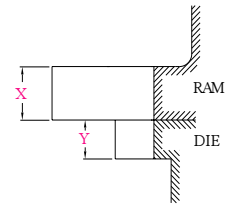

TYPE	Clamping force @ 3500 psi	Total stroke	Dimensions								'J' dim.	
			'A'	'B'	'C'	'D'	'E'	'F'	'G'	'H'	max	min
UNIT	lbs	in	in	in	in	in	in	in	in	in	in	in
SA40	8800	.32	6.25	3.50	7.125	4.095	1.969	.44	.875	1.812	2.25	.75
SA70	15400	.32	7.00	4.50	8.00	5.095	2.969	.56	1.022	2.125	2.5	.875